



IQ³⁺ PipeLine Metal Detection

www.loma.com

Versatile, proven metal detection systems for food, and other process industries



- **Versatile** A wide range of pipe diameters and fittings
- **Easy to use** Automatic product learn ensures maximum sensitivity without adjustment
- **Sensitive** Advanced signal processing provides unsurpassed levels of detection
- **Efficient** Fast acting application specific reject devices minimise product waste
- **Reliable** Heavy duty environmental protection even in the harshest of environments

Metal Detection

X-ray Inspection

Checkweighers

Data Capture

Designed to Survive



IQ³⁺ PipeLine Metal Detection

Finish:	304 stainless steel with bead blast finish	
Pipe Diameters: (nominal bore)	2.5" (57mm) Vacuum Filler applications for strip-down cleaning Typical products - Meat and Sausage	
	2" (48mm) 3" (73mm) 4" (98mm) General pumped applications with CIP cleaning Typical products - Liquids, Emulsions, Slurries and Pastes	
Mounting:	Stand on wheels with Gas Strut height adjustment L-Bracket for fixed installations	
Throughput:	Up to 10T/hr	
Fittings:	2.5" (57mm) Rd80 x 1/4" (6mm), Handtmann Quick Disconnect 2" (48mm), 3" (73mm) and 4" (98mm) Tri-Clamp Quick Release, 3A Bevel	
Adapter Options:	DIN11851, SMS, RJT	
Product Pipe:	Standard or water jacket	
Reject Valves:	Various according to application	
Environmental Protection:	IP 69K Keyboard cover supplied as standard	
Options:	Remote Control Box Beacon Stanchion Serial Link	PVS Indicator Lamp LomaEnet Remote Reports

Technical Specification

PVS to aid HACCP compliance

Various communication options to suit plant integration protocols

Direct transmitter drive to eliminate thermal drift

High field strength to eliminate external interference and deliver the ultimate in noise free detection

32-bit digital signal processing for enhanced contaminant detection

Hand Filler, Clipper and Linker Applications

Handtmann (VF50, 80, 100, 200, 300, 608, 610, 612, 616, 620, 622, 628, 630)

Vemag (HP7C, HP10C, HP15C, HP17C, HP25E, DP10C, DP15C, ROBBY-2)

Other Manufacturers easily accommodated

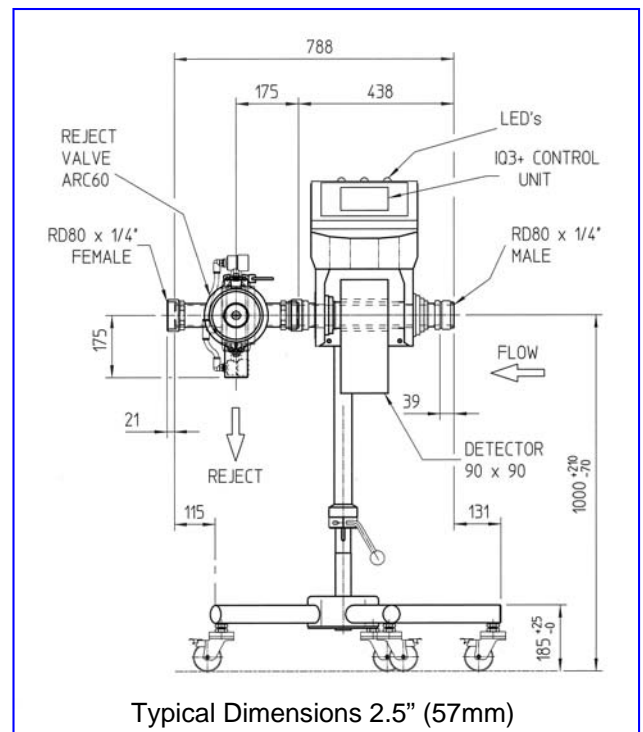

Loma Systems, Summit Ave, Southwood, Farnborough, Hampshire, GU14 0NY

Tel: +44 (0)1252 893300

Fax: +44 (0)1252 513322

Email: sales@loma.co.uk

Designed to Survive