



## *Ferrous in Foil Metal Detectors*

[www.loma.com](http://www.loma.com)

Versatile, proven ferrous in foil metal detection systems for the food and packaging industries



- **Versatile** Range of apertures to suite a wide range of product sizes
- **Easy to use** Automatic product learn ensures maximum sensitivity without adjustment
- **Sensitive** VLF high power coil drive eliminates interference and maximises sensitivity
- **Flexible** Multiple product memories for rapid product change over and data storage
- **Reliable** Heavy duty drives and conveyor parts for the harshest of environments

Metal Detection

X-ray Inspection

Checkweighers

Data Capture

*Designed to Survive*



# Ferrous in Foil Metal Detectors

Finish:	304 stainless steel with brushed finish		
Standard Line Height:	Feet:	750mm to 1000mm (50mm steps)	
	Wheels:	850mm to 1100mm (50mm steps)	
System Lengths:	Variable to suit application		
Belt Widths:	300mm	400mm	
Maximum Weights:	Flat PU Belt	30kg on the belt	
	Modular Belt	60kg on the belt	
Typical Belt Speed:	Up to 90 m/min		
Supply Voltages:	220/230V 1ph N+E or 380/415V 3ph N+E		
Air Supply:	5 to 8 bar		
Reject Types:	Stop on detect	<60kg	
	Air blast	<1kg	
	Pusher	<10kg	
	Carriage retract band	<5kg	
Environmental Protection:	IP 65 (minimum)		
Belt Type:	Flat (food quality) belt or Modular Belt		
Covers:	Stainless Steel		
Options:	Remote control box	Beacon stanchion	Keyboard cover
	Reject confirm	Bin full	LomaNet
	Ethernet	Serial link	Remote reports
	PVS Beacon	Makrolon covers	

## Technical Specification

Upgradeable metal detector controls

High power VLF coil drive

PVS to aid HACCP compliance

Various communication options to suit plant integration protocols

High field strength to eliminate external interference and deliver the ultimate in noise free detection.

32-bit digital signal processing for enhanced contaminant detection

Standard apertures on rapid delivery

Aperture heights = 134mm/184mm

Aperture Widths = 370mm/510mm

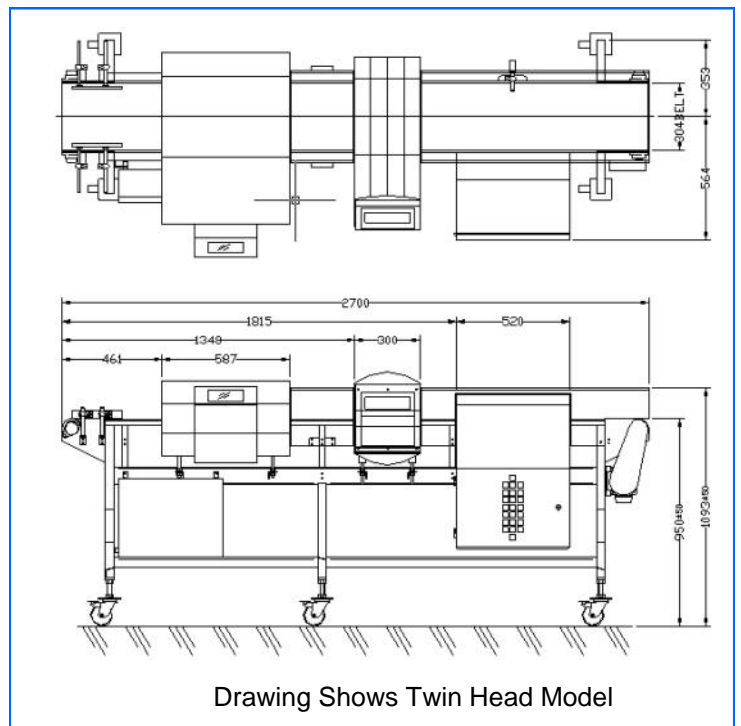

Loma Systems, Summit Ave, Southwood, Farnborough, Hampshire, GU14 0NY

Tel: +44 (0)1252 893300

Fax: +44 (0)1252 513322

Email: sales@loma.co.uk

