



IQ³ Metal Detector Conveyors

www.loma.com

Adaptable and tough variable frequency metal detection systems for the food, and packaging industries



- **Adaptable** True variable frequency detection adapts to new product and packaging in seconds
- **Easy to use** Automatic product learn ensures maximum sensitivity without adjustment
- **Stable** Unique case and coil geometry delivers unsurpassed levels of immunity
- **Flexible** Multiple product memories for rapid product change over and data storage
- **Tough** IP69K search head environmental protection

Metal Detection

X-ray Inspection

Checkweighers

Data Capture

Designed to Survive



Metal Detector Conveyors

Finish:	304 stainless steel with bead blast finish		
Standard Line Height:	Feet: 750mm to 1000mm (50mm increments) Wheels: 850mm to 1100mm (50mm increments)		
System Lengths:	1100 - 3000mm	1400 - 3000mm	1700 - 3000mm
	≤100mm	≤250mm	≤350mm
	Aperture	Aperture	Aperture
Standard Belt Widths:	300mm	400mm	500mm 600mm
Maximum Weights:	Flat PU Belt 30kg on the belt, Modular Belt 60kg on the belt		
Typical Belt Speed:	Up to 90 m/min		
Supply Voltages:	220/230V 1ph N+E, 380/415V 3ph N+E		
Air Supply:	5 to 8 bar		
Reject Types:	Stop on detect	<60kg	
	Air blast	<1kg	
	Pusher	<10kg	
	Carriage retract band	<5kg	
Environmental Protection:	Search Head IP 69K		
Belt Type:	Flat (food quality) belt or Modular Belt		
Options:	Beacon stanchion	Keyboard cover	Reject confirm
	Bin full	LomaEnet	Ethernet
	Serial link	Remote reports	
	PVS (Performance Validation System) Beacon		

Technical Specification

- Unique clam-shell design case and coil geometry
- Bifurcated and totally uniform product screen
- Upgradeable metal detector controls
- True variable frequency, standard operating range from 31 to 882KHz
- Performance Validation System (PVS) to aid HACCP compliance
- Various communication options to suit plant integration protocols
- 32-bit digital signal processing for enhanced contaminant detection
- Standard apertures on rapid delivery

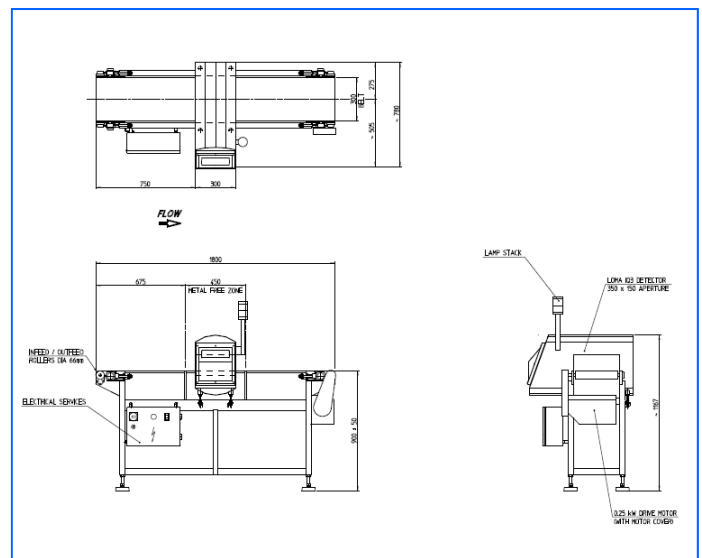

Loma Systems, Summit Ave, Southwood, Farnborough, Hampshire, GU14 0NY

Tel: +44 (0)1252 893300

Fax: +44 (0)1252 513322

Email: sales@loma.co.uk