

# ASHW

## Checkweighing



## Versatile, proven checkweighing systems for the food and packaging industries

Loma AS1500/5000

Loma AS1200

Loma ASHW

Loma ASDL

Loma ASCombo

### Summary

Our sales and design engineers work with you to provide a checkweighing system that is suitable to your individual application requirements.

The checkweigher range is the result of over 35 years of expertise in the food processing and packaging industry. Careful design has resulted in a modular product for ease of maintenance and minimum parts stocking requirement.

Loma's checkweighers are enhanced by the performance of a sister company's highly accurate and stable digital loadcell or Fast Intelligent Transducer – FIT, that maintains stability over extremes of temperature and humidity.

An essential part of any checkweighing system is an efficient reject device. Our sales and design engineers will ensure that the most effective device is selected for your individual application.

Loma produce a wide range of robust, reliable and user friendly models to meet industry needs, whether for packaged, bulk-fed or pumped product.

Loma delivers better, consistent quality to your product and plays a vital role in protecting your brand.



### Benefits at a glance:

- **Versatile** Bag or case weighing up to 60kg (132lbs) and up to 700mm long (27")
- **Reliable** Heavy duty conveyor components, high quality electronics
- **Accurate** FIT (Fast Intelligent Transducer) digital loadcell
- **Stable** Low profile control unit minimises unwanted mechanical vibration

## Benefits of Checkweighing

Automatic Checkweighers have been used in the food processing and packaging industry for over 30 years so the technology is well tried and tested.

National weight legislation ensures that manufacturers comply with weight requirements for the goods that they are producing. Lack of compliance can lead to prosecution. An automatic checkweigher not only inspects every pack but produces records to demonstrate compliance. Most weight legislation is concerned with the production of underweight goods. However, a checkweigher can control the production of over-weight goods and in so doing reduce give-away, this enhances profitability. Some applications (such as tea and coffee production) offer the opportunity of enhancing profitability further by applying servo feedback control to the volumetric filler. Payback for such an installation can be in the order of weeks.

The weight and production data gathered by in-line checkweighers can also be used to provide valuable information on line efficiencies when linked to a Data Management System. This information can be viewed remote from the line on a central PC or several PC's networked together. A checkweigher can also be linked to a SCADA system (Supervisory Control and Data Acquisition) in order to fully integrate it into a plant automation system.

Checkweighing plays a vital role in protecting the brand and conforming to national weight legislation.

Finally, remember first class pre and after sales support is key to success. Training at the time of installation, spare parts availability, regional support, cross trained technicians, and help lines must be considered as part of the purchase.

## Technical Specification

Digital filtering at over 600 samples/sec

Application specific filtering

Automatic mean weight correction AMC

Sample packs function

Multi-product memory

0.25kW AC drive motor

65mm (2.56") diameter precision rollers

High capacity loadcell

## About Loma Systems

Loma Systems is a world class manufacturer of inspection systems, with installations in over 60 countries and in most of the world's largest food and packaging companies.

Loma Systems holds ISO 9001 certification and has earned a reputation for the consistent quality and advanced technology of its products, the results of a continuous and far-reaching research and development program.

Short lead times, modular design together with our passion for customer service, allow you to:

1. Maximize your production up-time.
2. Maintain your self-sufficiency.
3. Help your customers comply with and exceed consumer and government demands for product safety.



All Loma systems are manufactured to the exacting standards of ISO9001 and supported by a world-wide network of sales and service operations

Loma reserves the right to improve or change specification without prior notice

|                          |  |                      |
|--------------------------|--|----------------------|
| Finish:                  | 304 stainless steel with bead blast finish   |                      |
| Typical Line Height:     | 600mm ± 75mm   | 24" ± 3"             |
| System Length:           | 800mm  | 32" (without reject) |
| Maximum Weight:          | 60kg   | 132lb                |
| Maximum Product Width:   | 500mm  | 20"                  |
| Maximum Product Length:  | 700mm  | 27.5"                |
| Typical Accuracy, Un:    | 6g   | 0.2oz                |
| Supply Voltages:         | 110 or 230V/1ph/N+E 50 or 60Hz   |                      |
| Belt Type:               | Flat (food quality) belt   |                      |
| Standard Reject Options: | Signal Only  |                      |
| Environment:             | IP55   | NEMA12               |
| Standard inclusions:     | Adjustable feet, Pack pitch monitor, Printer (Europe)  |                      |
| Options:                 | Servo feedback - for filler control, Serial link, LomaNet, Ethernet, Heavy duty pusher reject (on separate conveyor) |                      |

## System Drawing

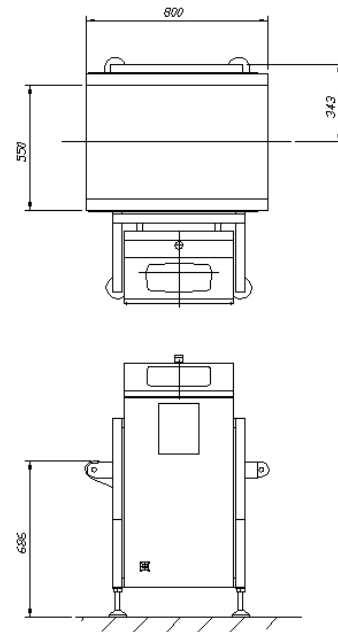

|   |   |   |  |  |  |  |  |
|---|---|---|--|--|--|--|--|
| <b>UK</b><br>Loma - Cintex<br>Southwood, Farnborough<br>Hampshire, GU14 0NY<br>England<br>tel +44 1252 893300<br>fax +44 1252 513322<br>e-mail<br>sales@loma-cintex.com | <b>USA</b><br>Loma Systems<br>283 East Lies Road<br>Carol Stream, Illinois 60198<br>USA<br>tel +1 800 USA LOMA<br>tel +1 630 588 0900<br>fax +1 630 588 1394<br>e-mail sales@loma.com | <b>Canada</b><br>Loma Systems Canada<br>333 Wycroft Road<br>Oakville, Ontario,<br>Canada<br>tel +1 800 387 7987<br>tel +1 905 842 4581<br>fax +1 905 842 3460<br>e-mail:<br>lomacanada@loma.com | <b>China</b><br>Spectris China Ltd<br>Unit 101<br>XinAn Plaza<br>Building 13<br>No 99, Tianzhou Road<br>Shanghai 200233<br>PR China<br>tel +86 21 611 33688<br>fax +86 21 611 33788<br>e-mail:<br>stevenfang@spectris.com.cn | <b>France</b><br>Loma - Cintex<br>120 rue Jean Jaurès<br>92300 Levallois Perret<br>France<br>tel +33 1 55 69 57 78<br>fax +33 1 55 17 43 31<br>e-mail:<br>info@loma-cintex.com | <b>Germany</b><br>Loma - Cintex<br>Vahrenwalder Straße 269A<br>30179 Hannover,<br>Germany<br>tel +49 511 9666 811<br>fax +49 511 9666 812<br>e-mail:<br>info@loma-cintex.com | <b>The Netherlands</b><br>Loma - Cintex<br>Panovenweg 22<br>5708 HR Helmond,<br>Netherlands<br>tel +31 492 573 573<br>fax +31 492 573 570<br>e-mail:<br>info@loma-cintex.com | <b>Czech Republic</b><br>Loma - Cintex<br>U Lomy 1069, 334 41<br>Dobruška<br>tel +420 377 183811<br>fax +420 377 183820<br>e-mail:<br>info@loma-cintex.com |
|---|---|---|--|--|--|--|--|