



AS 1500 & 5000 Checkweighers

www.loma.com

Versatile, proven checkweighing systems for the food and packaging industries



- **Versatile** Weighs a wide range of flexible and rigid packs up to 5kg
- **Accurate** Excellent accuracy, especially with flexible packaging
- **Fast** Belt speeds up to 70m/min
- **Reliable** Heavy duty conveyor components, high quality electronics
- **Accredited** OIML R51 approved

Metal Detection

X-ray Inspection

Checkweighers

Data Capture

Designed to Survive



Checkweighing Systems

Finish:	304 stainless steel with bead blast finish
Typical Line Height:	900mm ± 75mm
Typical System Length:	1,500mm
Maximum Weight:	5,000g
Maximum Product Width:	400mm
Maximum Product Length:	625mm
Typical Accuracy, Un:	0.6g
Capacity:	300ppm
Supply Voltages:	110 or 230V/1ph/N+E 50 or 60Hz
Air Supply:	5 to 8 bar
Standard Reject Options:	Air Blast, Pusher, Diverter
Environment:	IP55/IP66
Belt type:	Flat (food quality) belt
Standard inclusions:	Adjustable feet, Reject bin (Europe), Printer (Europe), Multi speed, Pack pitch monitor
Options:	Multi speed, Servo feedback - for filler control, Serial Link, LomaNet, Ethernet. Super ruggedized hose - down specification

Technical Specification

Digital filtering at over 600 samples/sec

Application specific filtering

Automatic mean weight correction AMC

Sample packs function

Multi-product memory

90W motors on AS1500

90W constant torque drive motor on AS5000

High capacity loadcell

R51 Approved AS1500

X(0.5) e = 0.5g

R51 Approved AS 5000

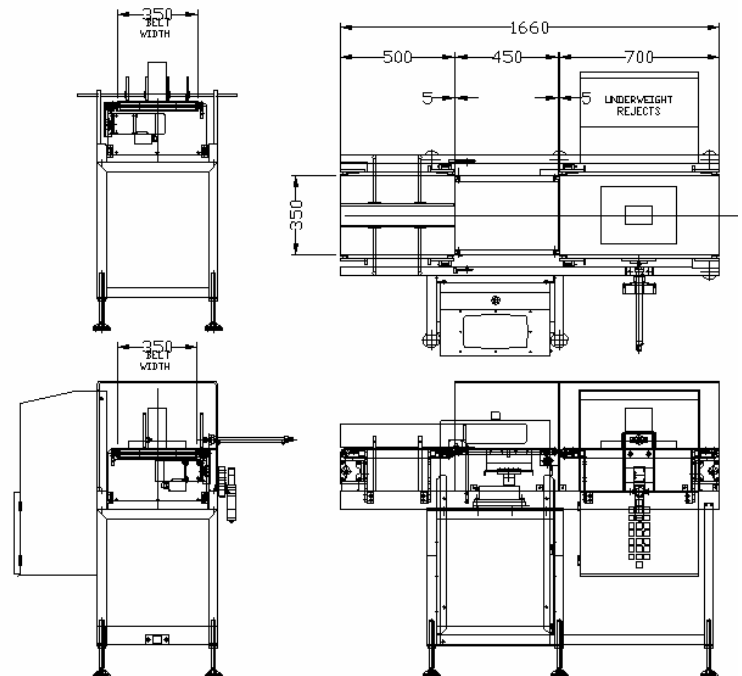

Loma Systems, Summit Ave, Southwood, Farnborough, Hampshire, GU14 0NY

Tel: +44 (0)1252 893300

Fax: +44 (0)1252 513322

Email: sales@loma.co.uk

Designed to Survive